

Best choice, Brightest price

KOLIDA

SPECIFICATION

	KTS-442	KTS-442L	KTS-442R	KTS-445	KTS-445L	KTS-445R
Measuring Range						
1P	2.0km	5.0km	5.0km	2.0km	5.0km	5.0km
No prism			300m			300m
Digital Display	Maximum: 99999999.999 Minimum: 1mm					
Accuracy	With prism: 2+2ppm Without Prism:5+3ppm					
Measuring Time	KTS-440:Fine3s Tracking 1.0s KTS-440L/R:Fine 1.0s Tracking0.5s					
Atmospheric Correction	Automatic Correction by Inputting Parameter					
Prism Constant	Automatic Correction by Inputting Parameter					
Angle Measurement						
Measurement Method	Absolute Encoding					
Diameter of The Raster Disk	79mm					
Minimum Reading	1" / 5" Optional					
Accuracy	2"		5"			
Detection Method	Horizontal: Dual		Vertical: Dual			
Telescope						
Image	Erect					
Length	154mm					
Effective Aperture	45mm, (DTM: 50mm)					
Magnification	30 X					
Field of View	1° 30'					
Resolving Power	3"					
Minimum Focus	1m					
Vertical Compensation						
System	liquid-electric detection					
Working Range	± 3'					
Accuracy	6"					
Sensitivity of Vials						
Plate Vial	30" / 2mm					
Circular Vial	8' / 2mm					
Optical Plummet						
Image	Erect					
Magnification	3×					
Focusing Range	0.5m~∞					
Field of View	5°					
Display						
Type	Dual sides					
Battery						
Power Supply	Rechargeable Ni-H battery					
Voltage	6 VDC					
Operation Time	10 hours					
Dimension & Weight						
Dimension	160mm×150mm×330mm					
Weight	5.8 kg					

ACCESSORIES (OPTIONAL)



Reflector Prism System
ADS 17(Single) ADS30(Triple)



Dia.:25.4mm
Offset:-17.5/-7.5mm
Mini Pole:30cm×4, Φ 10mm

Mini Prism System ADSmini112A



ATS-1(Aluminum) ATS-2(Wooden)
Prism Pole & Prism System ADS107



KTS-440/440L/440R SERIES

TOTAL STATION

Dealer Info

KOLIDA
KOLIDA INSTRUMENT

GUANGDONG KOLIDA INSTRUMENT CO., LTD.
Add: 3/F, HaiWangBuilding, Tian He Industrial Park, Ke Yun Road, Guangzhou 510665, China
Tel: +86-20-85542075 Fax: +86-20-85542136
E-mail: export@kolidainstrument.com http://www.kolidainstrument.com

KTS-440 Infrared Light Total Station

Labyrinth Type Structure

Angle Measurement by Raster Disc

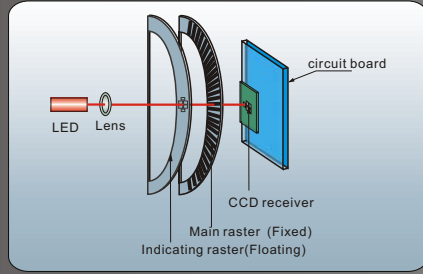

Labyrinth type structure IP 33 Class

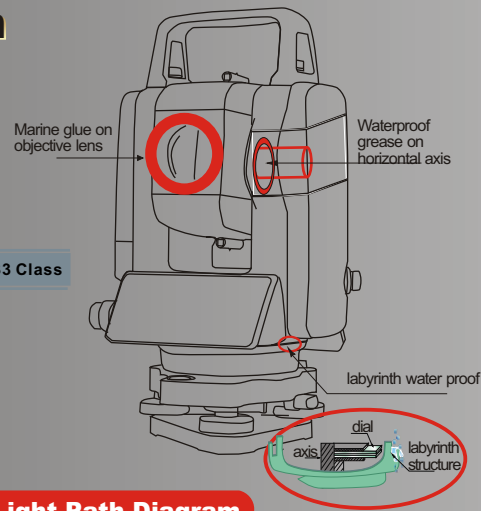

Circuit Diagram

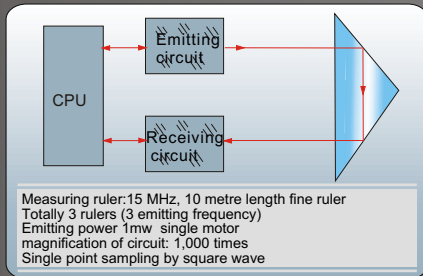

Infrared Light Path Diagram

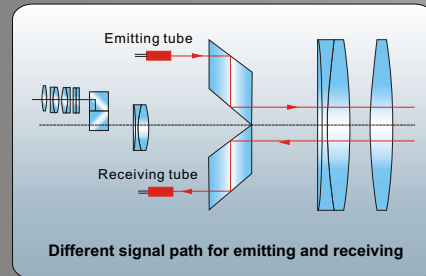

KTS-440L/R Laser Total Station

Circuit Diagram

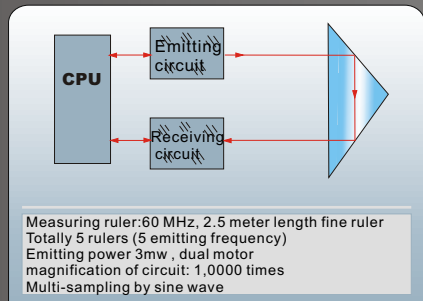

All in one board, World Class Technology

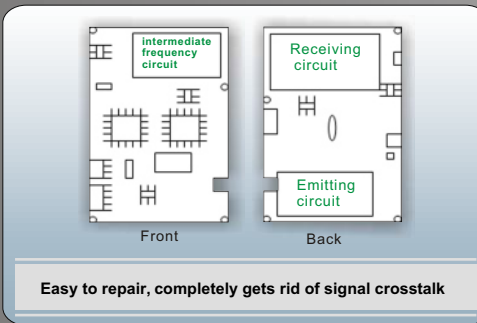

Rubber Circle for Water Proof

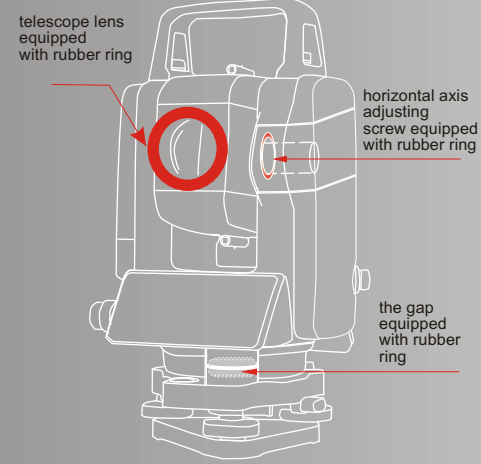

Laser Path Diagram

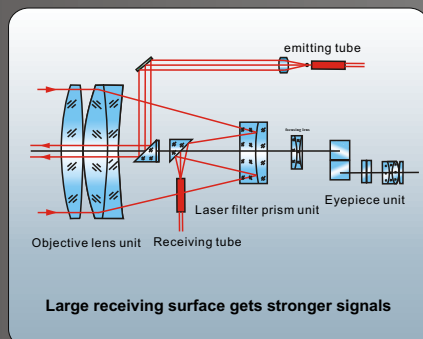

Angle measurement by Absolute Encoding Disc

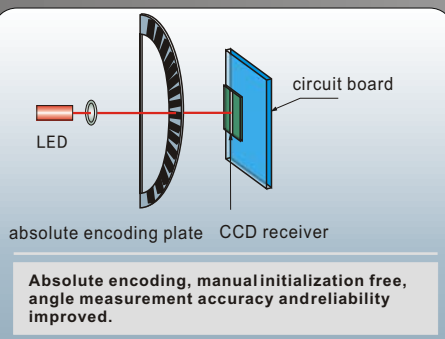

APPLICATION OF KTS-440R

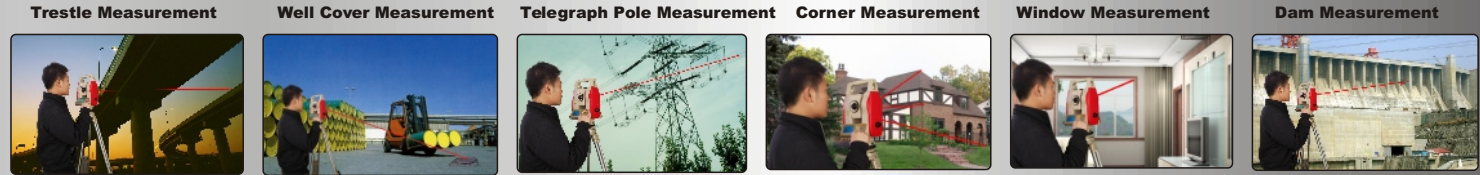

COMPARISON OF KTS-440 AND KTS-440L/R

	KTS-440	KTS-440L	KTS-440R
Angel Measurement	2 x Photoelectronic-Incremental discs. Silicon photocell detector. Need initialization before measurement.	1x absolute encoding disc. CCD detector, more stable, easier for repair, no initialization.	
Distance Measurement	GaAs diode, big emitting angle, small receiving surface.	Red laser emitting tube. Larger receiving surface for signal collection	Same with 440L
Measurement Time	Fine: 1.5s Tracking 1.0 s	Fine: 1s Tracking 0.5 s	
Measurement Ruler	15 MHz, 10 meters length fine ruler Totally 3 rulers (3 emitting frequency)	60 MHz, 2.5 meters length fine ruler Much more precise. Totally 5 rulers (5 emitting frequency)	
Range	Single prism 2km	Single prism 5km	
Capability	Emitting power 1mw magnification of circuit: 1,000 times single motor Single point sampling by square wave	Emitting power 3mw magnification of circuit: 10,000 times Dual-motor Multi-sampling by sine wave	Emitting power 10mw reflectorless measuring range 300m with Visible laser
Water proof type	labyrinth type structure, proofs against light rain, IP 33 Class	Rubber Circle in most positions, proofs against water/ dust/ damp. IP55 Class	Same with 440L

ABUNDANT ADD-IN PROGRAM

